

Status update

- ER2 wafers arrived on Monday afternoon
 - Installation in WP and SW configuration
 - First measurements indicated shorts and issues with setup (Impedance measurements with open and short connections)
 - Move on to powering (did not trust impedance measurement hardware)
 - Similar issues on Services Domain with low impedance (order single digit Ohm)
- Debugging on Tuesday with much less people
 - Silkscreen on Probecard validated manually
 - Tested multiple dies with same behaviour
 - Chip designers found a potential issue in design – pressure to confirm
 - Move to single needles/manipulators – not compatible with the wafer prober
 - Made metal adapter plates for the micromanipulators in the workshop
- Wednesday installed the micromanipulators to probe single nets
 - Confirmed that there is NO short on the chip services supply
 - Huge relief
 - Potential culprit – Probecard pinout (i.e. how the needles were soldered to the pcb)
 - Later confirmed
- Thursday:
 - Now re-test with re-worked Probecard

Status update

- Quote from Fe55 source:

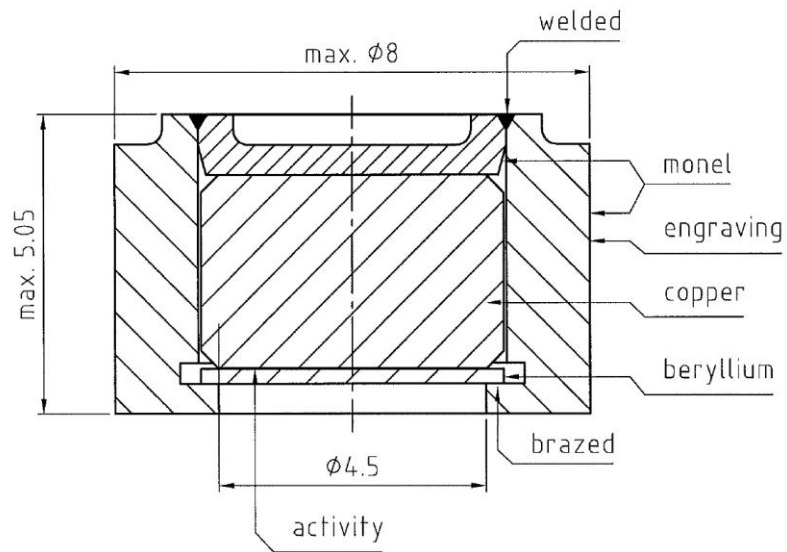

Mehr sehen, gezielt therapieren – medeo. Mieux voir, thérapie ciblée – medeo.



CERN Site de Meyrin
Radiation Protection Group
RP Shipping Service (Bat. 194) Entree D
Route de Meyrin
1211 Genève 23

Offer	
Receipt number	101252
Page	1/1
Date	17.02.2026
Customer number	1179
TAV No	CHE-103.594.335 MWST

Reference		Order number	
Your sign	Sebastien Boucy	Our sign	Marcel Langensand
Delivery date			

Pos	Part-No.	Description	Quantity	Price	Total	VAT
1	IECB24690	Gamma Source Fe-55, 500 MBq Activity tolerance: ±15% Drawing: VZ-2878-001 Dimensions: Ø 8 mm x 5 mm Active diameter: 3.5 mm ANSI/ISO class: ISO/12/C54243	1	5'800.00	5'800.00	206
2	TRSP KL. 7	import handling & shipment costs acc. to the rules of SDR/ADR, class 7	1	500.00	500.00	206
Subtotal					CHF	6'300.00
Taxfree organisation (6'300.00) VAT 206						0.00
Total					CHF	6'300.00

Conditions: 30 days net

Validity : December 31, 2026

Delivery delay : 6 to 8 weeks after receipt of order

First measurements on 5x babyMOSAIX

- Power up global services
 - Exercise node slow control
 - Service nodes
- Power up global analog/digital GAVDD/GDVDD
 - Core slow control responsive
 - Tiles can be powered up – successful (so far 100%)
 - Can connect local analog monitoring to analog out and read local tile supplies

First measurements on 5x babyMOSAIX

- Power up global services
 - Exercise node slow control
 - Service nodes
- Power up global analog/digital GAVDD/GDVDD
 - Core slow control responsive
 - Tiles can be powered up – successful (so far 100%)
 - Can connect local analog monitoring to analog out and read local tile supplies
- Metal stack paper accepted – waiting for proof
- Cable high-speed test fixture arrived

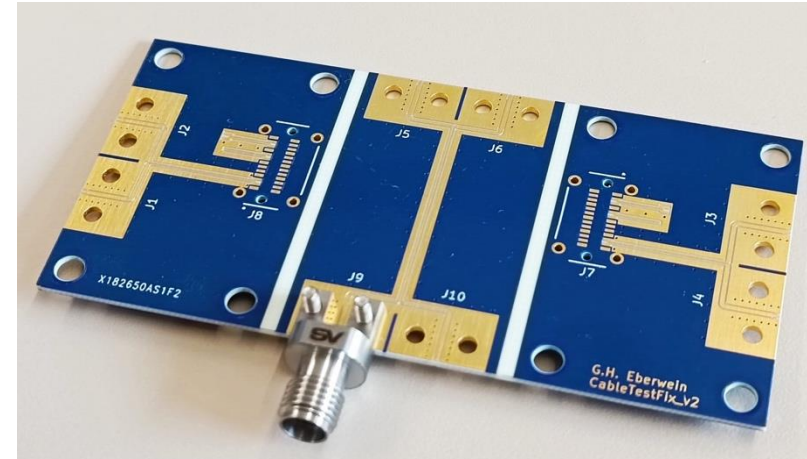

backup



ER2 arrival

- Wafers received @CERN 16. Feb 2026
 - Lot of 25
- Sorted (partially ITS3 subset for immediate thinning and dicing)
 - First wafer selected for testing

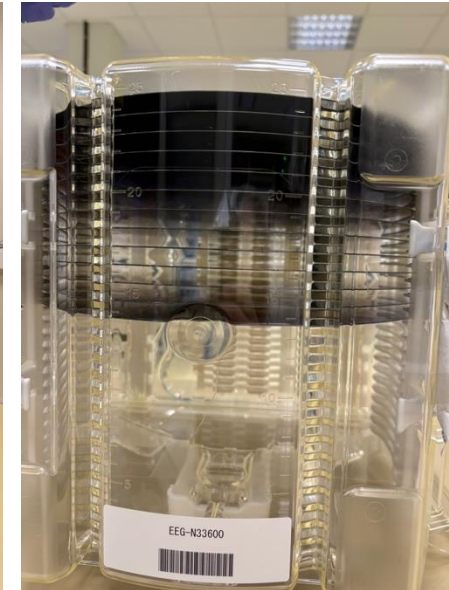
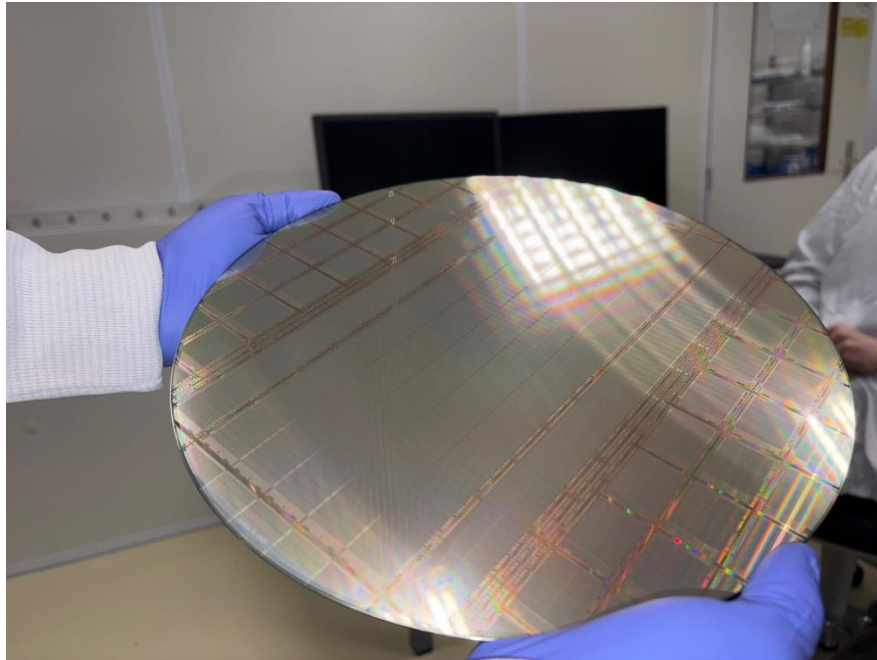

ER2 recap

- 5x MOSAIX
- 20x babyMOSAIX
- +50x chiplets

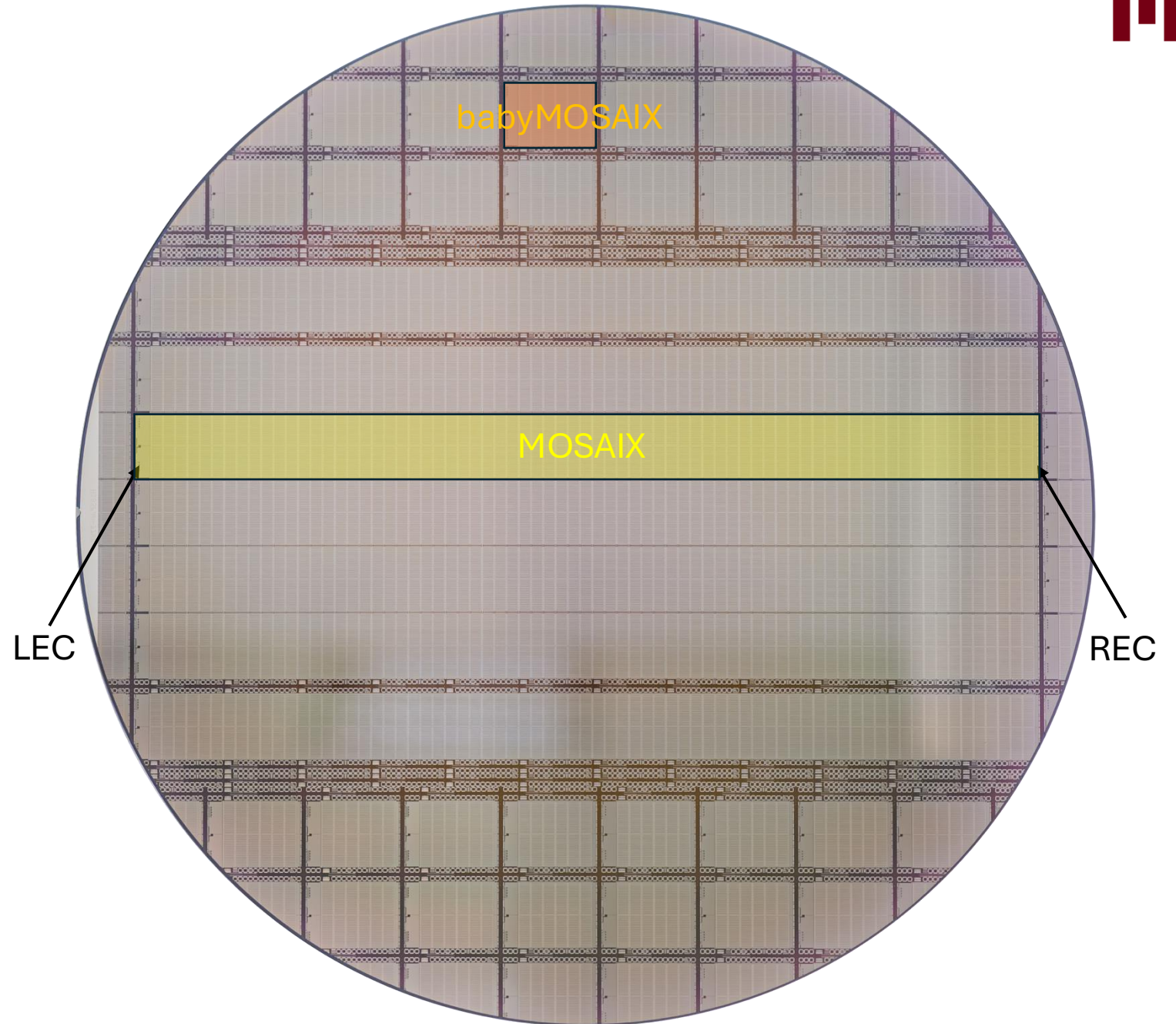

First wafer probing tests

- Day 1 readiness for tests – large effort by ITS3 team (SW/FW/HW)
- Cantilever probecard (low speed) installed in MIT prober, only setup used for first tests
 - Vertical probecard (high-speed) expected next week

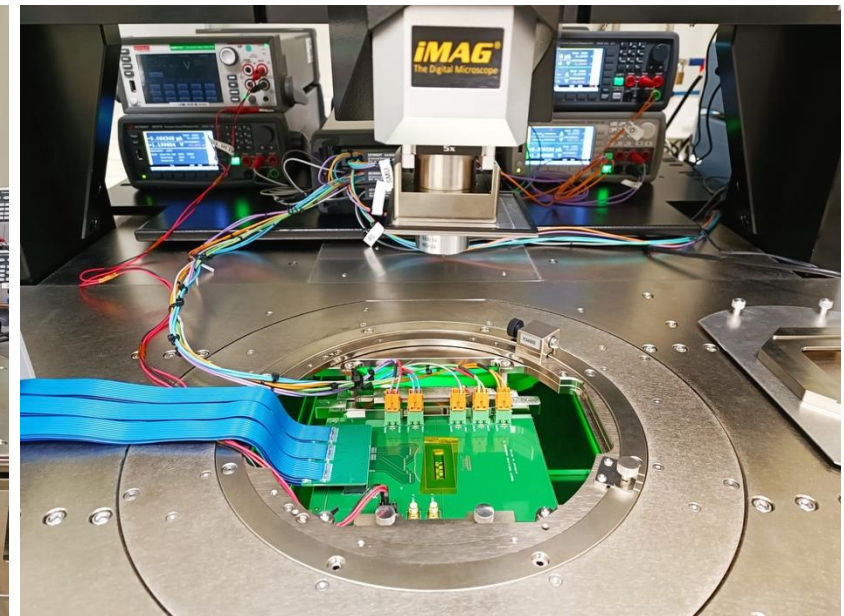
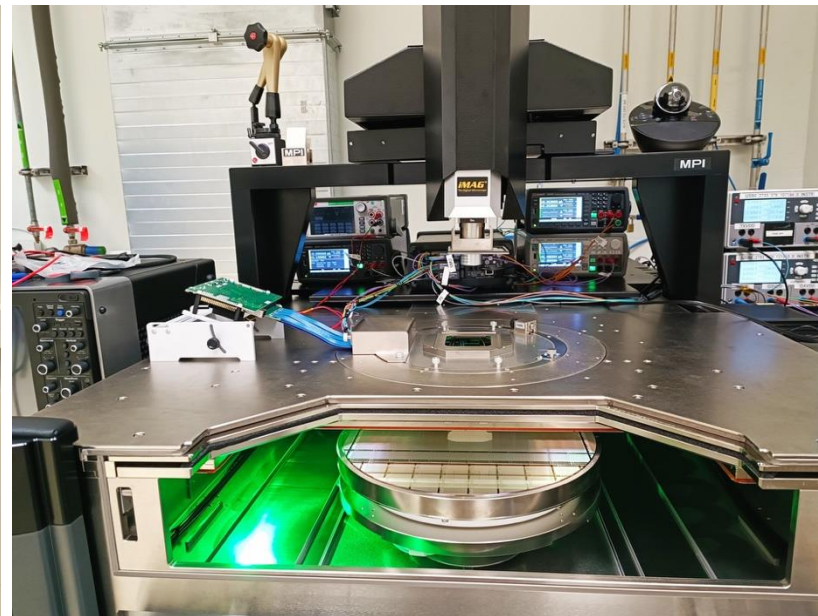
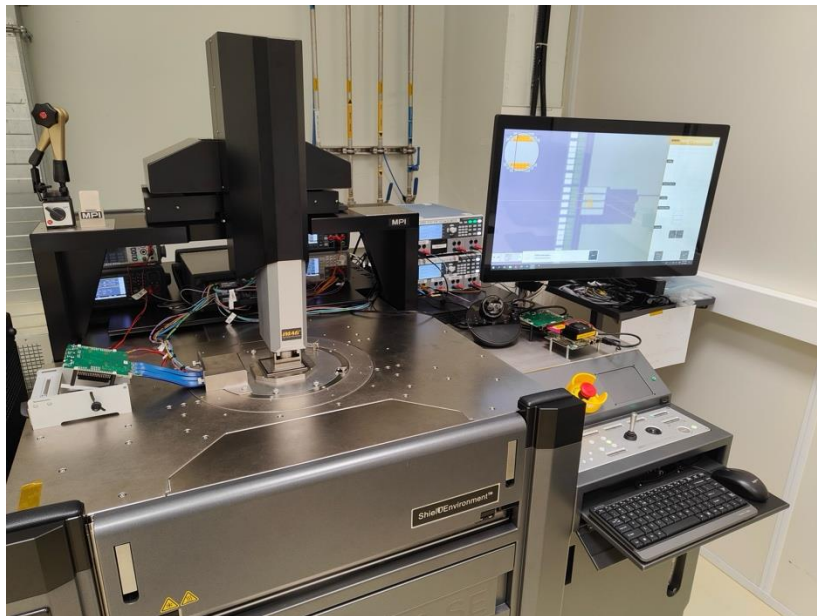

Readiness for probing @MIT waferprober

- Wafer maps were prepared for both babyMOSAIX and MOSAIX using the padwafers
 - ER2 wafers were contacted right after selection of wafer

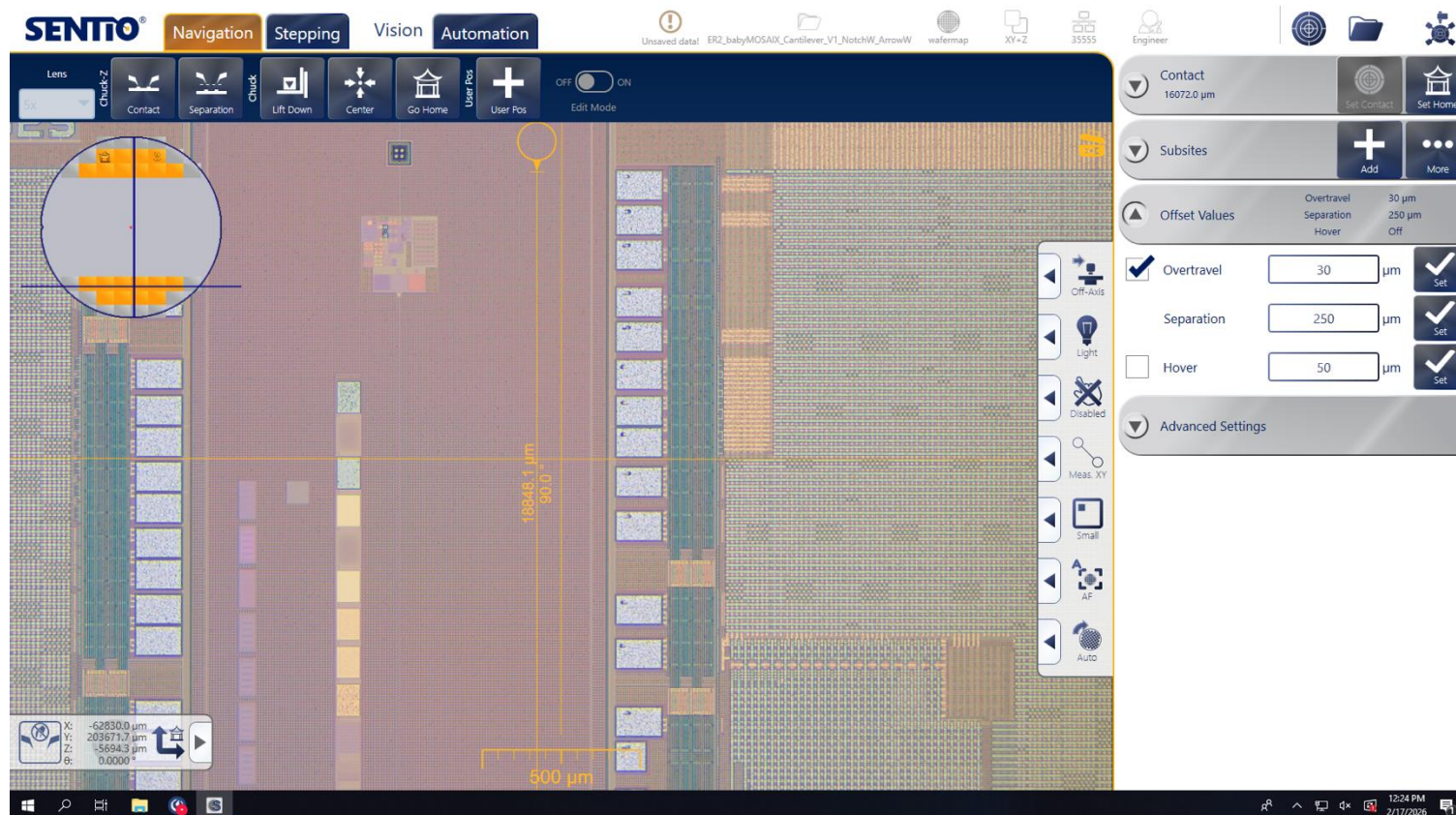

First tests on ER2

- Performed on babyMOSAIX
- Impedance test (-50mV to +50mV scan)
 - Check if there are shorted power domains on-chip
- Power step ramps (ramp-up domains sequentially)
 - Global services domain (GSVDD)
 - Followed by a slow control endpoint check, service nodes needed for tile power switches
 - Global digital and analog domains (GDVDD, GAVDD)
 - Power up tiles by setting service node registers
 - Connect local tile supply monitoring to analog monitoring rail and out-pad

Impedance tests and debugging

- First tests showed concerning GSVDD-GSVSS short
 - Blocked any other tests in sequence
- Immediate debugging needed:
 - Nets probed with adapted micromanipulators
 - No shorts on chip!

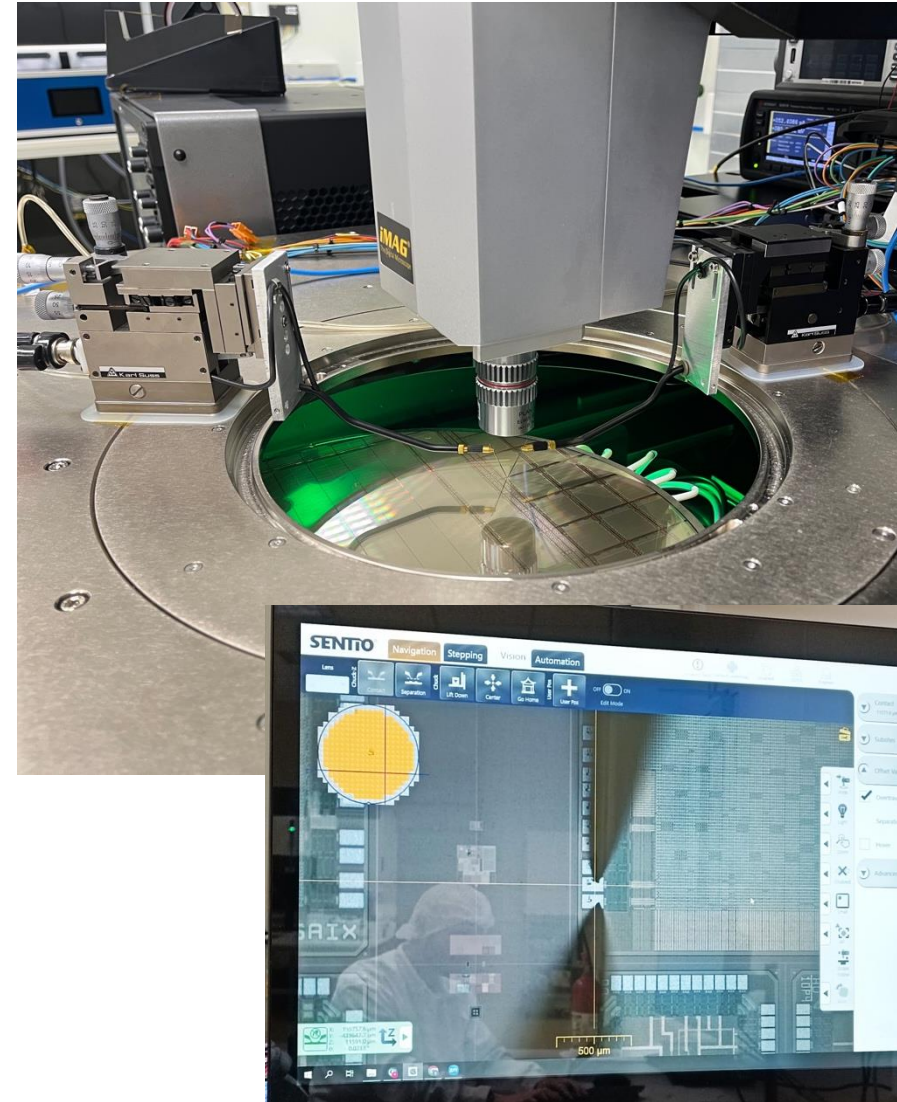

Impedance tests and debugging

- First tests showed concerning GSVDD-GSVSS short
 - Blocked any other tests in sequence
- Immediate debugging needed:
 - Nets probed with adapted micromanipulators
 - No shorts on chip!
 - Made ad-hoc test fixture for probing the probecard
 - Confirmed needle swaps
 - Reworked @CERN
 - Debugged and patched in ~ 4 days

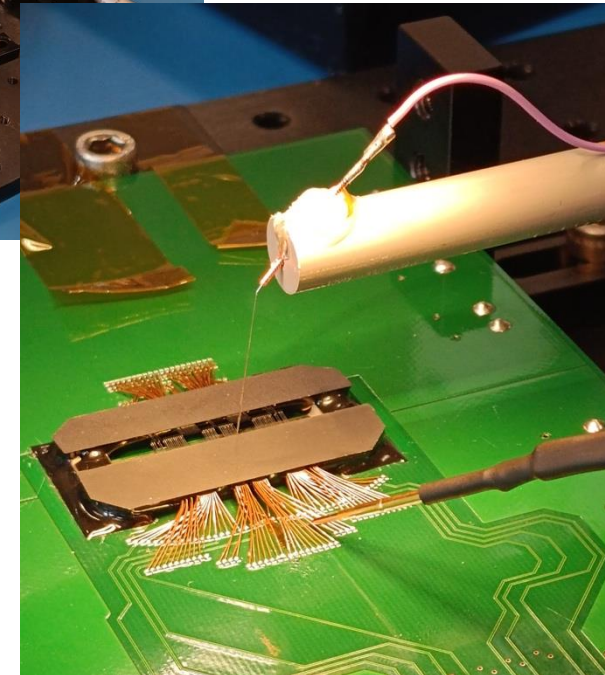

Power ramp-up – global services

- Global services ramped up
 - Reasonable current consumption
- Now one can talk to the chip
 - Reading/writing to services slow control endpoints confirmed
 - Debugged a FPGA locking issue, stable afterwards

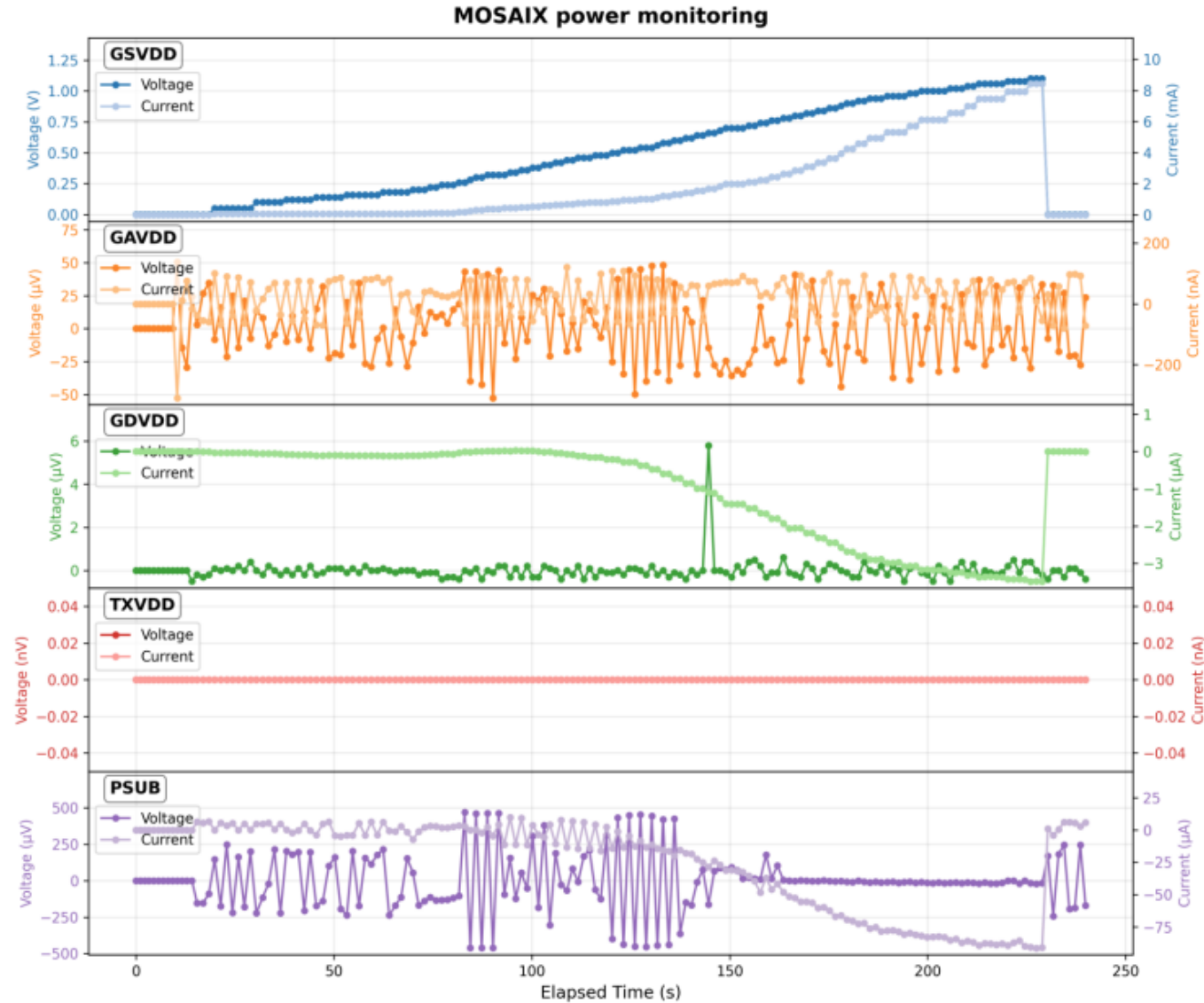

Power ramp-up – global services

- Global services ramped up
 - Reasonable current consumption
- Now one can talk to the chip
 - Reading/writing to services slow control endpoints confirmed
 - Debugged a FPGA locking issue, stable afterwards
- Service nodes can be reached

```
mosaix[0]:sn-USA[0,0]> read-all-registers
INFO [2026-02-25 14:48:10.186]: Reading all readable registers from hardware...
INFO [2026-02-25 14:48:10.188]: Read 6 readable registers from hardware
mosaix[0]:sn-USA[0,0]> dump-registers
INFO [2026-02-25 14:48:12.081]: Dumping ServiceNode USA[0,0] registers to screen...
INFO [2026-02-25 14:48:12.081]: ===== Register Dump for ServiceNode_USA[0,0]_GSA[0] =====
INFO [2026-02-25 14:48:12.081]: Name | Address | Mode | ConfigValue | SwValue | HwValue | HwSync | ConfigSy
INFO [2026-02-25 14:48:12.081]: TILE_POWER_SWITCHES_CFG | 0x0000 | RW | 0x0000 | 0x0000 | 0x0000 | Y |
INFO [2026-02-25 14:48:12.081]: ANALOG_MONITORING_CFG | 0x0001 | RW | 0x0000 | 0x0000 | 0x0000 | Y |
INFO [2026-02-25 14:48:12.081]: SBB_TILE_SER_CFG | 0x0002 | RW | 0x0000 | 0x0600 | 0x0600 | Y |
INFO [2026-02-25 14:48:12.081]: TILE_RESET_CONTROL | 0x0003 | RW | 0x0000 | 0x0007 | 0x0007 | Y |
INFO [2026-02-25 14:48:12.081]: GATE_SRV_NODE_ENDPOINT_RESPONSE | 0x0004 | RW | 0x0000 | 0x0000 | 0x0000 | Y |
INFO [2026-02-25 14:48:12.081]: SCRATCH | 0x0005 | RW | 0x0000 | 0x000A | 0x000A | Y |
INFO [2026-02-25 14:48:12.081]: ===== End Register Dump =====
mosaix[0]:sn-USA[0,0]> █
```



Power ramp-up – global digital/analog

- Successful power-up of the global domains (GSVDD, GDVDD, GAVDD)

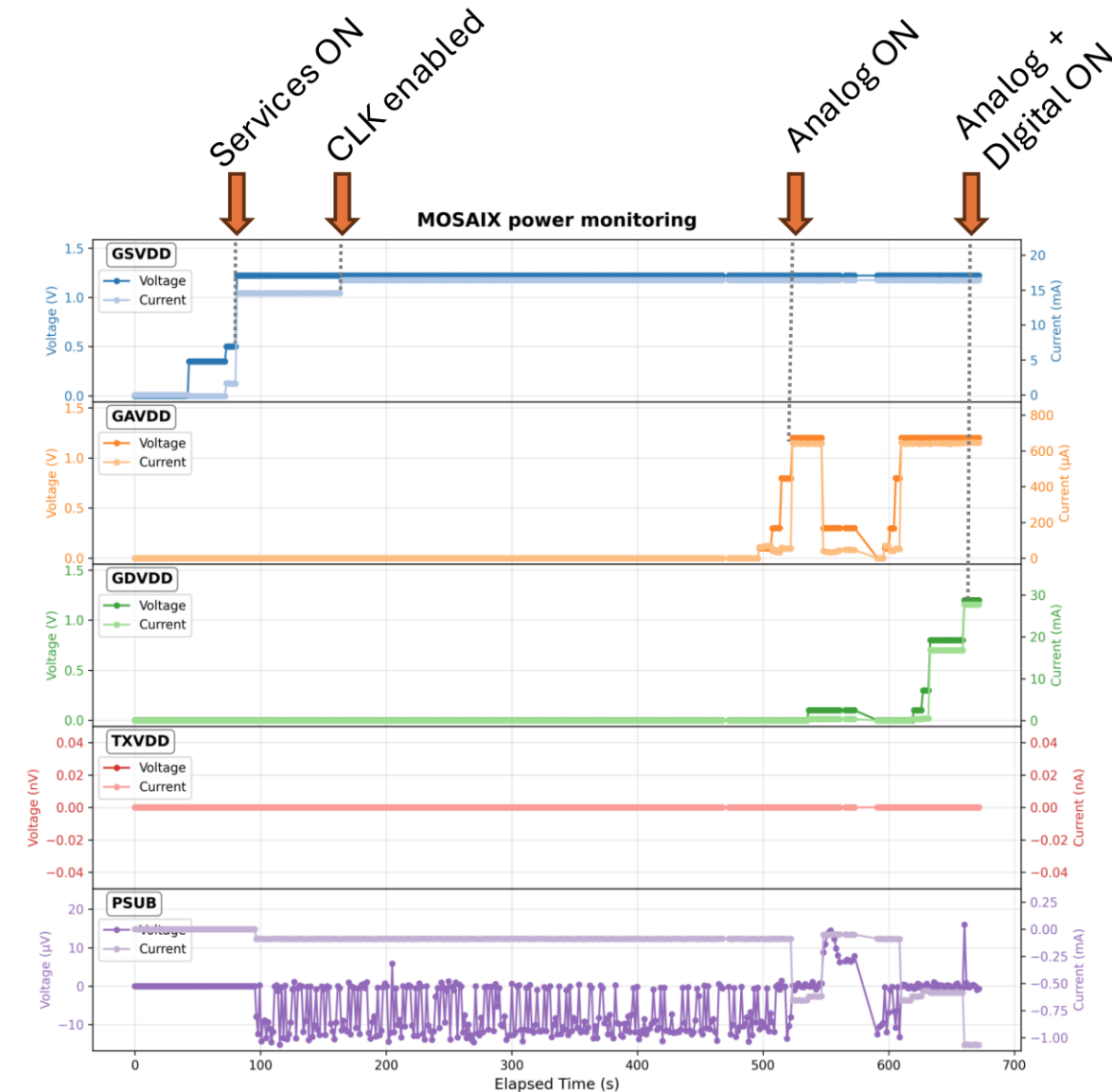

Power ramp-up – tiles

- Successful power-up of the global domains (GSVDD, GDVDD, GAVDD)
 - Now, tiles can be turned on
 - Also, all tiles powered successfully

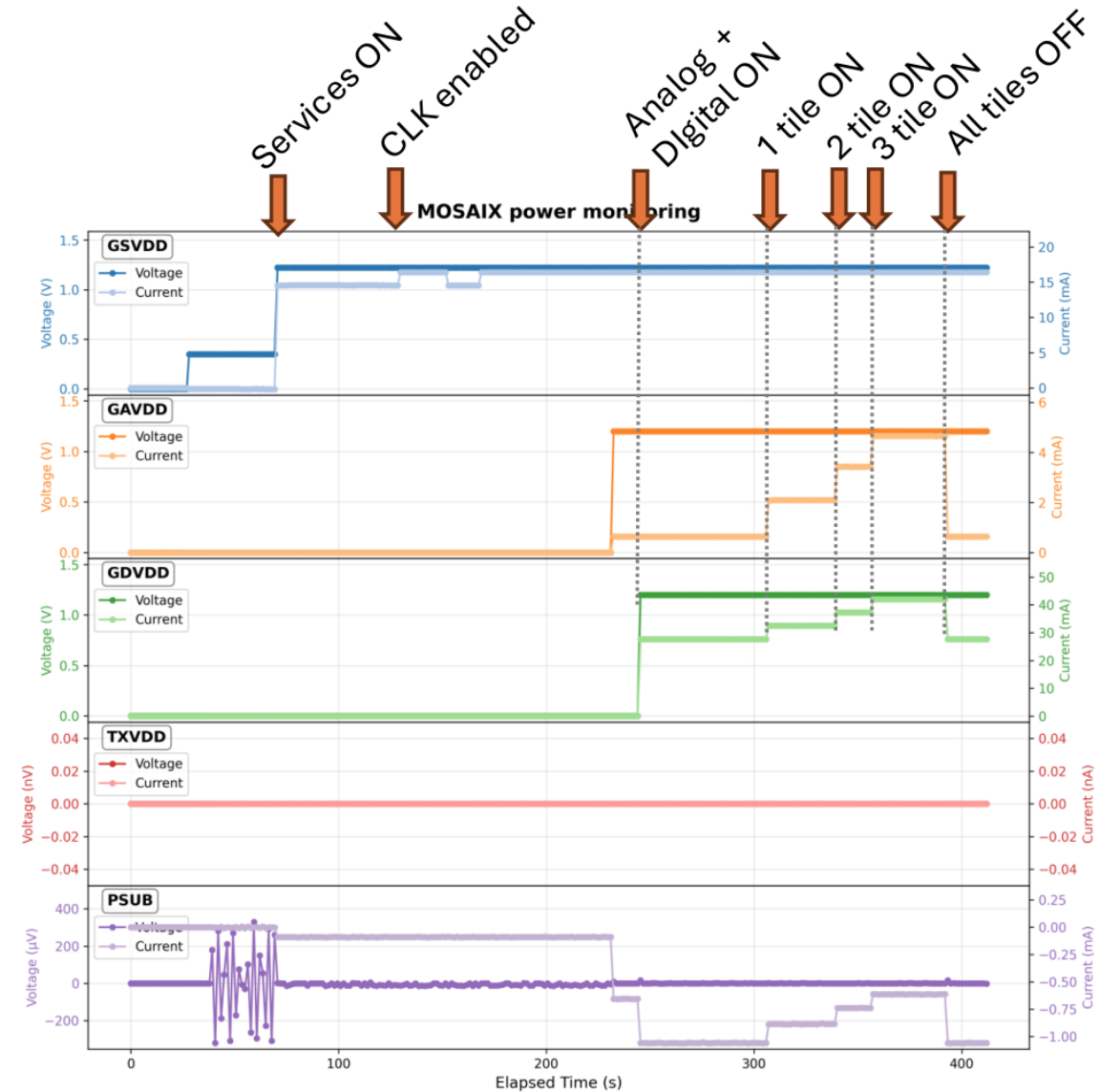

Power ramp-up – tile monitoring preview

- Tile registers read and written
- Monitoring features working
 - Measured local tile supplies and currents via analog monitoring rail

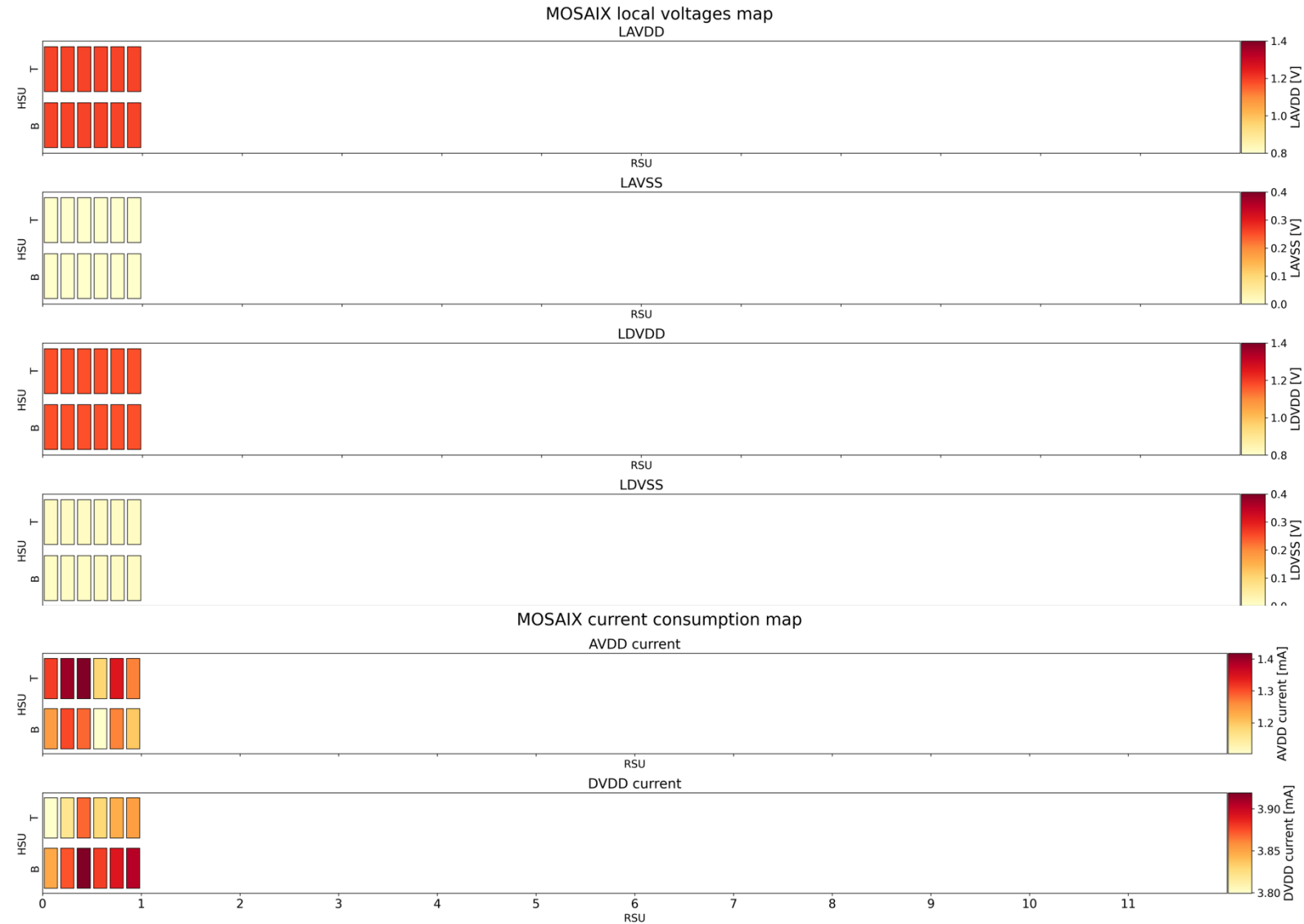

Summary

- Day 1-readiness for testing achieved
- Probe card issue resolved quickly (~ few days)
 - High-speed probe card expected next week
- Very fast progress after probecard fix
 - Domain independence confirmed (impedance test)
 - Power up services and full babyMOSAIX
 - Service and Core slow control functional
 - Monitoring feature exercised for local supply level
- Smaller refinements being implemented and systematic testing to be resumed