

DarkLight at ARIEL

Dipole Magnet Spectrometers

Experiment layout

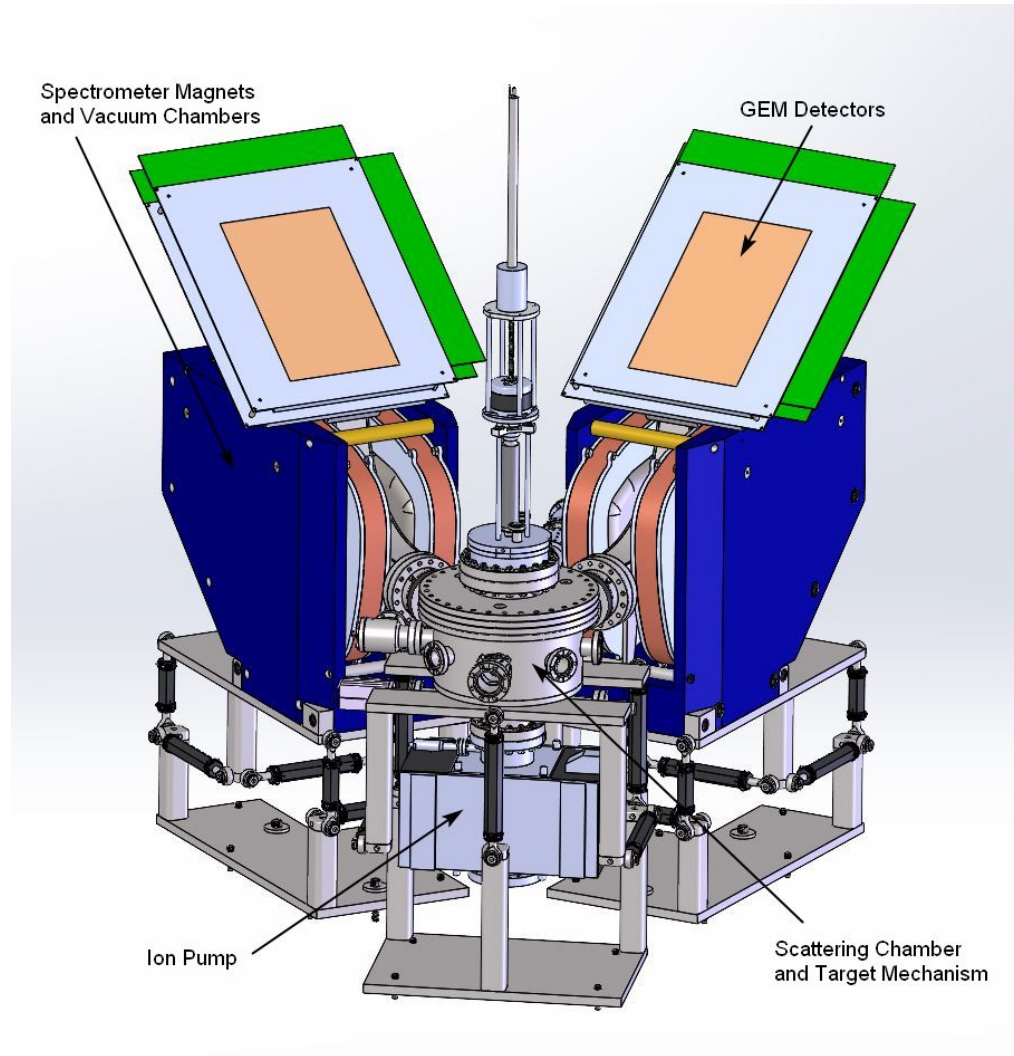
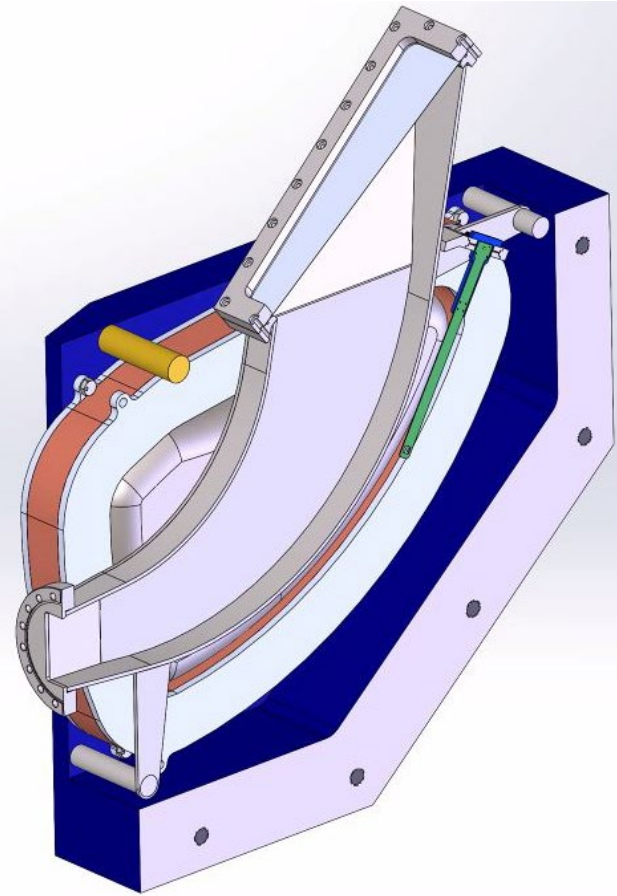
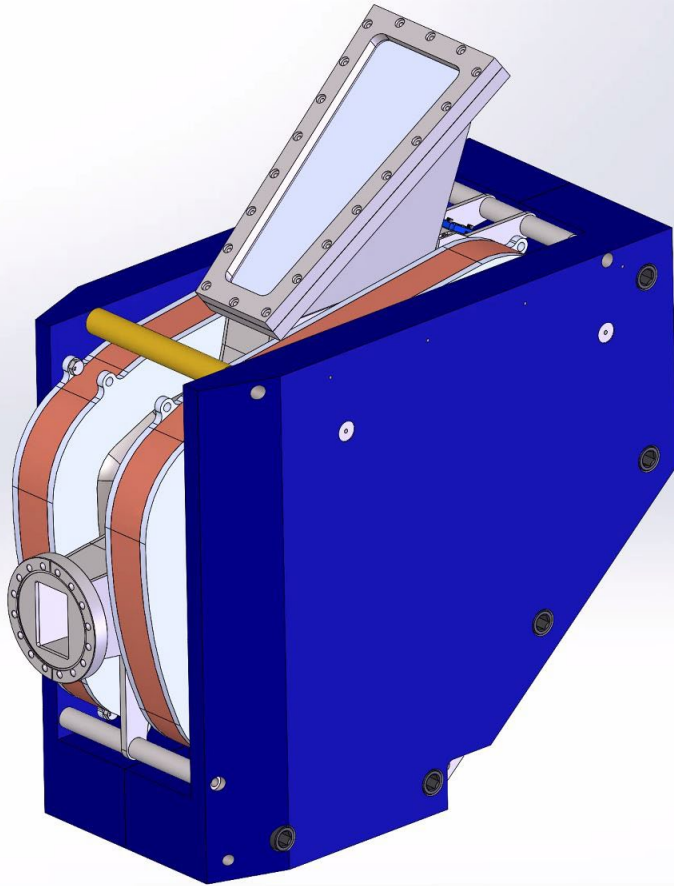

Dipole Magnet Spectrometer



Dipole Magnet Spectrometer (revised 2023)

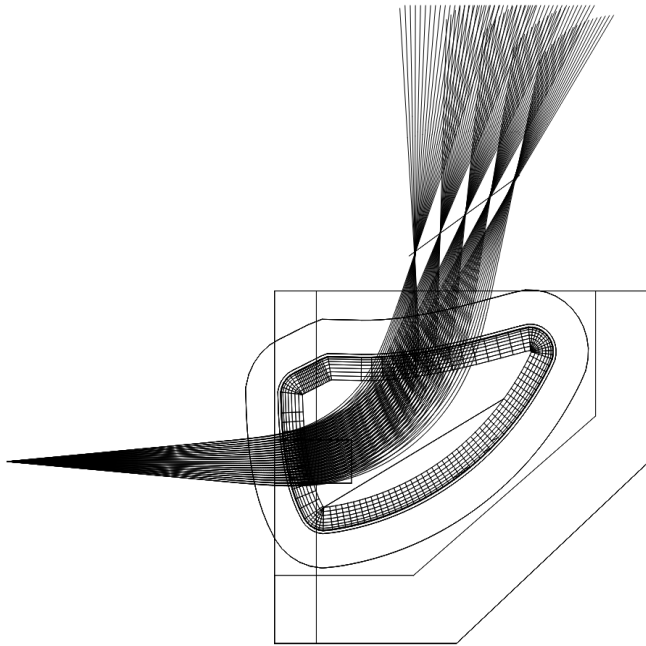

- Result based on geometry: **Only 30 MeV electrons**, 80 mm gap, 30 cm bend radius, pole design from Harald.
- Field Now - Use 3.4 kilogauss in design
- NI per coil is 11,000 amp turns per coil
- Ribbon wound coils , potted water-cooling plates.
- Current in coils: 229 amps, Resistance of one coil: $.03 \Omega$, Voltage per coil; 7.5V
- Power per coil: 1.8 kW. Water cooling. 1.5 liter/min (.3 gpm), Delta T: 25 C. $V=2$ ft/s
- Design iteration done to match vendor stock and make faster.

Dipole Magnet Spectrometer

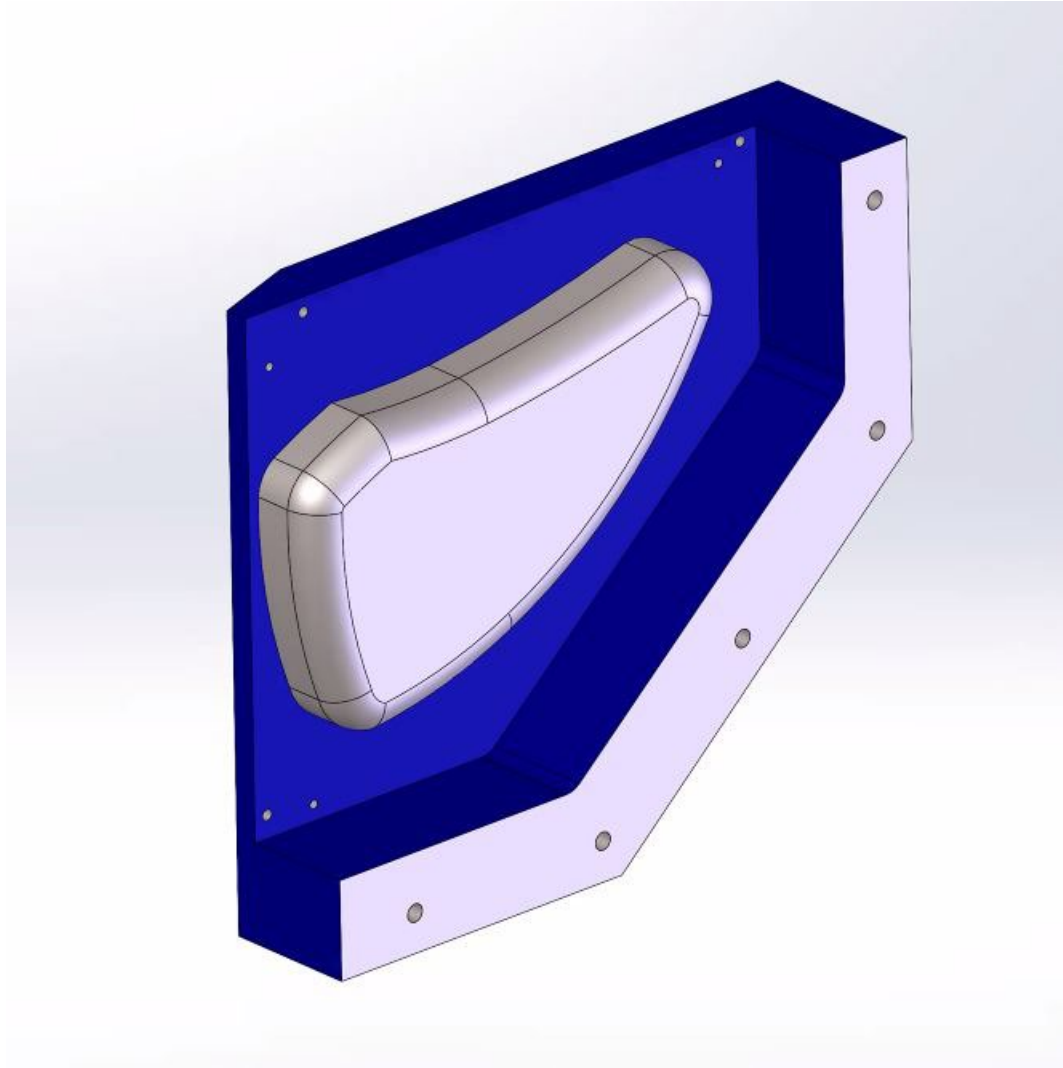

ANSYS Analysis by Xiaqing Li

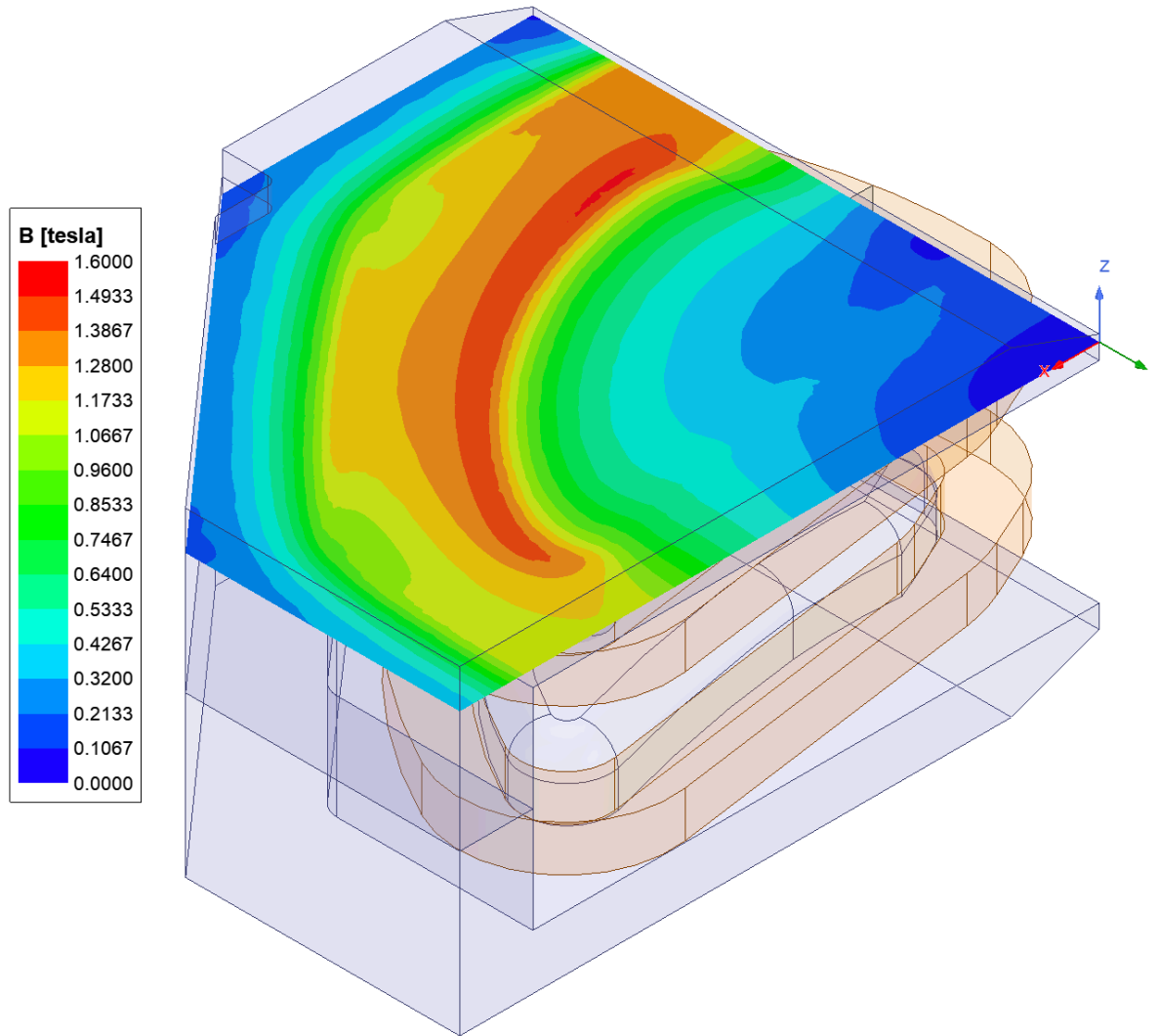

Ray trace by Doug Hasell

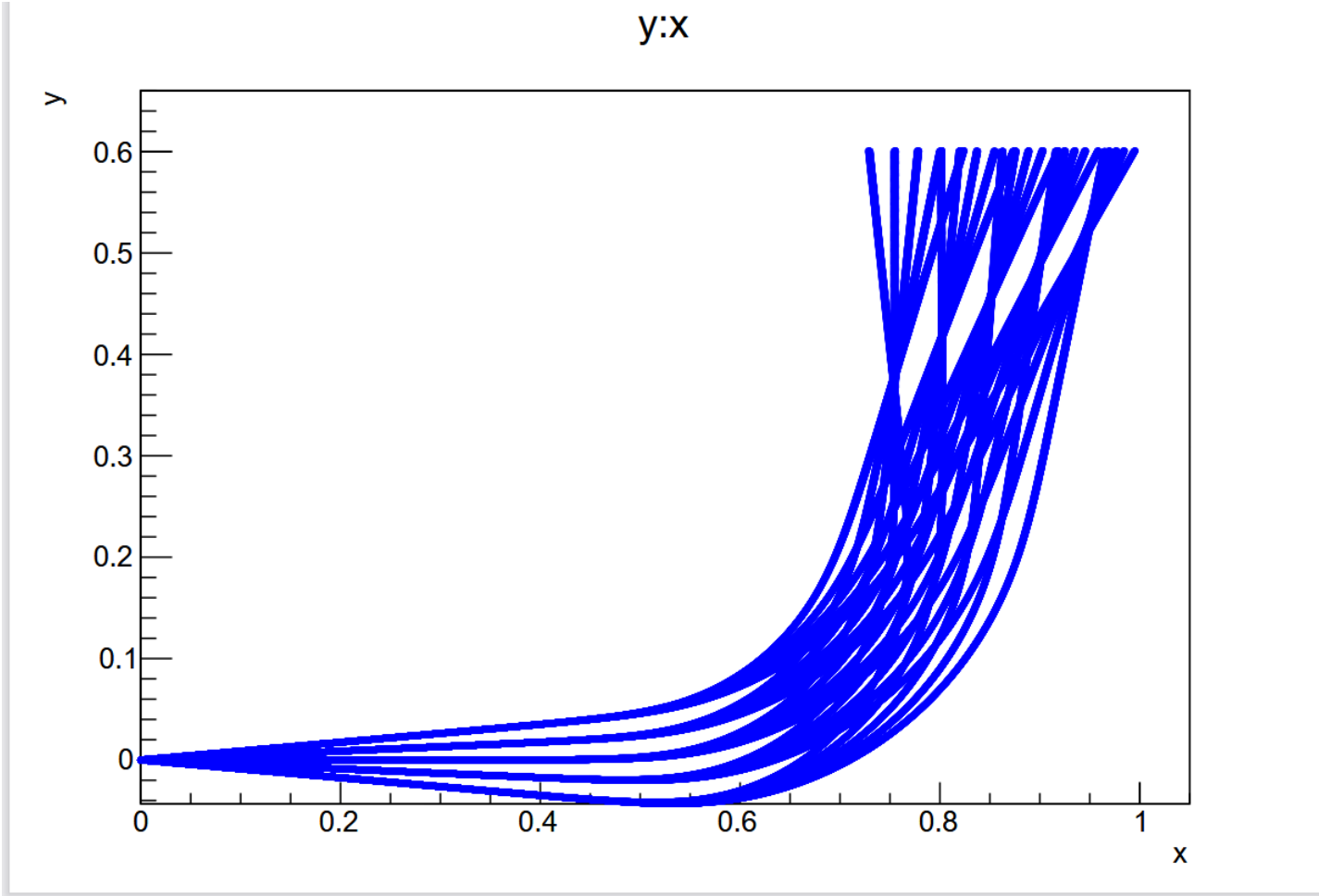

Summary

- The iteration of the magnet design was required because of extremely long delivery times for hollow core conductor from Luvata. An air cooled version was not possible to reach field in limited space.
- The steel yoke was completely redesigned by Chris and I based on feedback from a vendor on how to machine it the fastest. I will explain during my talk the approach we took. Quotes in hand for steel.
- The move to ribbon wound coils was necessary to make the magnet with vendor in house stock ribbon. The vendor has the steel, conductor and multiple CNC machines to do this task.
- I was unable to design a system that met any requirements with the allowable spacing for coils. New power supplies have been selected but I want to iterate with Truimf on AC input power and distance for DC cables to ensure I have enough voltage (250V,20V). Delivery expected to be much faster based on the design changes. The vendor has the steel, conductor and multiple CNC machines to do this task.
- A hall probe from Pyramid is included in the design to monitor field during experiment .
- Mass of magnet assembly is 787 kg.
- Metric hardware will be used.
- Will meet with ARIEL survey group to ensure we have adequate tooling for survey.